



SITE ADDRESS: 231 Union Station Plaza, Bethlehem, PA

File Copy

Office Use Only:

DATE SUBMITTED: _____ HEARING DATE: _____

PLACARD: _____ FEE: _____

ZONING CLASSIFICATION: _____ LOT SIZE: _____

**APPLICATION FOR APPEAL TO THE CITY OF BETHLEHEM ZONING HEARING BOARD,
10 E. CHURCH STREET, BETHLEHEM, PA 18018**

1. Return one (1) original and seven (7) copies of this application and all supporting documentation to the Zoning Officer, along with the filing fee. Include site plans and/or floor plans as necessary.
2. *THE APPLICATION IS DUE BY 4 PM THE LAST WEDNESDAY OF THE MONTH FOR THE NEXT MONTH'S ZONING HEARING BOARD MEETING. MEETINGS ARE GENERALLY THE FOURTH WEDNESDAY OF THE MONTH. ONLY COMPLETE SUBMISSIONS WILL BE ADDED TO THE AGENDA FOR HEARING.*

Appeal/Application to the City of Bethlehem Zoning Hearing Board is hereby made by the undersigned for: (check applicable item(s)):

- Appeal of the determination of the Zoning Officer
- Appeal from an Enforcement Notice dated _____
- Variance from the City of Bethlehem Zoning Ordinance
- Special Exception permitted under the City Zoning Ordinance
- Other: _____

SECTION 1

APPLICANT:	
Name	Adams Outdoor Advertising
Address	2176 Avenue C
	Bethlehem, PA 18017
Phone:	[REDACTED]
Email:	[REDACTED]

OWNER (if different from Applicant): Note. If Applicant is NOT the owner, attach written authorization from the owner of the property when this application is filed.	
Name	PA Lines LLC c/o Norfolk Southern Railway Com
Address	110 Franklin Road SE Roanoke, VA 24042
Phone:	[REDACTED]
Email:	[REDACTED]
ATTORNEY (if applicable):	
Name	Attorney James F. Preston - Broughal & DeVito, L.L.P.
Address	38 West Market Street Bethlehem, PA 18018
Phone:	[REDACTED]
Email:	[REDACTED]

SECTION 2. INFORMATION REGARDING THE REAL ESTATE

1. Attach a site plan, drawn to scale, of the real estate. Include existing and proposed natural and man-made features.
2. If the real estate is presently under Agreement of Sale, attach a copy of the Agreement.
3. If the real estate is presently leased, attached a copy of the present lease.
4. If this real estate has been the object of a prior zoning hearing, attach a copy of the Decision.

SECTION 3.

THE RELIEF SOUGHT:

If the Applicant seeks a dimensional variance for any setback, lot coverage, distance between certain uses, etc., please state the following:

Section of Code	Dimension Required by Code	Dimension Proposed by Applicant	Variance Sought
_____	_____	_____	_____
_____	SEE ATTACHED REASONS FOR APPEAL		_____
_____	_____	_____	_____
_____	_____	_____	_____

If the Applicant seeks a use or other variance, please state the **specific section(s)** of the Zoning Ordinance applicable and describe the variance sought.

SEE ATTACHED REASONS FOR APPEAL

If the Applicant seeks a Special Exception, please state the **specific section (s)** of Zoning Ordinance applicable:

N/A

If the Applicant seeks an appeal from an interpretation of the Zoning Officer, state the remedy sought in accordance with Sec. 1325.11 (b):

N/A

NARRATIVE SEE ATTACHED REASONS FOR APPEAL

A brief statement reflecting why zoning relief is sought and should be granted must be submitted.

CERTIFICATION

I hereby certify that the information contained in and attached to this application is true and correct to the best of my knowledge and belief.

J. Amzyski
Applicant's Signature

8.3.17
Date

Robert J. Colwell agent for Norfolk Southern
Property owner's Signature

8-3-17
Date

Received by

Date

BEFORE THE ZONING HEARING BOARD OF THE CITY OF BETHLEHEM

IN RE: APPEAL OF ADAMS OUTDOOR ADVERTISING

Appellant's Supplemental Statement

This is an Appeal from the denial of a permit to construct and operate an off-premises sign at certain real property along route 378 in the City of Bethlehem ("Permit Application"). The Permit Application, dated July 14, 2017 - requesting a permit for the real property identified as 231 Union Station Plaza (parcel #210204E) - is incorporated herein in its entirety as a material part of this Appeal. The Appellant is appealing the denial of its Permit Application in its totality with specific reference to the following provisions of the City of Bethlehem's Zoning Ordinance ("Z.O.") identified in the denial.

Z.O § 1320.09(b)(3)(ii) [sign area]

Variance from Z.O § 1320.09(b)(3)(ii)

ZO section 1320.09(b)(3)(ii) limits off-premises signs along route 378 to a maximum sign area of 100 Sq. ft. The Appellant requests a variance from Z.O. § 1320.09(b)(3)(ii) to allow the construction and operation of an off-premises sign in accordance with the Permit Application. In particular, the Appellant seeks allowance to install and operate a sign with a sign area of 616 sq. ft. along route 378 as set forth in the Permit Application.

Validity Challenge to Z.O § 1320.09(b)(3)(ii) [in the alternative]

In the alternative, the Appellant challenges the validity of Z.O. § 1320.09(b)(3)(ii) as applied to the Permit Application. A zoning regulation will be found to be invalid where it is shown to be unreasonable and not substantially related to a legitimate police power purpose.

A zoning regulation is unreasonable and not substantially related to a legitimate police power purpose if it is shown to be arbitrary or unduly restrictive. The City's Zoning Ordinance permits off-premises signs along route 378; however, the Z.O. restricts such signs to a maximum sign area of 100 sq. ft. This area limitation applies exclusively to signs along route 378. Appellant believes, and therefor avers, that the 100 sq. ft. area limitation on the otherwise permitted sign use along route 378 is unreasonable, arbitrary, and not substantially related to the police power interest that the ordinance purports to serve. The City's allowance of signage along route 378 in excess of the Ordinance's area limitation confirms the arbitrary and unreasonable nature of this limitation. To wit: The City allows a 672 sq. ft. sign along 378 at the Hill to Hill bridge; the City agreed to a 625 sq. ft. sign near the 13th avenue overpass at route 378; and, as recently as 2016, the City issued a permit to operate a 672 sq. ft. sign adjacent to route 378 near the route 378 interchange with route 22.

ZO § 1320.07(s)(7)

Favorable interpretation of, or variance from, ZO § 1320.07(s)(7) [isolation distance]

The sign described in the Permit Application is an off-premises digital sign. Z.O. § 1320.07(s)(7) requires that any off-premises digital sign shall be set back a minimum of 1,000 feet from any other off-premises digital sign. The Appellant request a favorable interpretation of, and/or a variance from, Z.O. § 1320.07(s)(7) to allow its sign to be placed at the location indicated in the Permit Application. There is an existing off-premises digital sign on the opposite side of route 378 that is within 1000 feet of Appellant's proposed sign; however, the Appellant believes that the isolation distances set forth in ZO § 1320.07(s)(7) apply to signs within a defined ROW, and not to signs located in an opposing ROW. Such an interpretation is consistent with PennDOT's application of isolation distance requirements. In the alternative, the applicant requests a variance from ZO § 1320.07(s)(7) to allow its digital sign to be located as described in the Permit Application.

Z.O § 1320.09(b)(3)(ii) [sign height]

Variance from Z.O § 1320.09(b)(3)(ii)

Z.O § 1320.09(b)(3)(ii) limits the height of signs along route 378 to not more than 25 feet above the “basic grade”. The Permit Application describes a freestanding sign approximately 40 feet above the structure of the route 378 bridge. There are unique physical circumstances associated with the location of the proposed sign such that strict application of Z.O § 1320.09(b)(3)(ii), as the Appellant understands that section, would create an unnecessary hardship. Consequently, the Appellant is requesting a variance from Z.O § 1320.09(b)(3)(ii) to allow the placement of the sign at the height described in the Permit Application.

Respectfully submitted,

Broughal & DeVito LLP

By: 

James F. Preston, Esq.

Jodi Cesanek

From: Roberts, Christina M <CRoberts@bethlehem-pa.gov>
Sent: Monday, July 24, 2017 8:46 AM
To: Jodi Cesanek
Subject: 231 Union Station Plaza - permit application

Your permit application to install an off premise sign at the subject location has been denied by the zoning officer for the following reasons:

Per Article 1320.09.b.3.ii: Maximum size of signs on Route 378 shall not exceed one square foot of sign area for each 2' of lot frontage or 100 square feet, whichever is small.
Verify that the maximum height above SR 378 will be no more than 25'.
Indicate distance between this proposed billboard and all existing billboards.

If you have any questions regarding the above comments please contact the Zoning Officer, Suzanne Borzak, at 610-997-7640.

Tina Roberts

Permit Coordinator
Code Enforcement
City of Bethlehem
10 E. Church Street
Bethlehem, PA 18018
610-865-7263

We'll be here **TO MORROW** to back up what we say **TO-DAY**



July 14, 2017

Ms. Suzanne Borzak
Zoning Officer
City of Bethlehem
10 E. Church Street
Bethlehem, PA 18018

JUL 14 2017

RE: 231 Union Station Plz - Parcel #P6 21 0204E

Dear Suzanne:

Please find enclosed an Application for Permit along with two (2) copies each of the following documents:

- Site Plan prepared by Barry Isett & Associates (EX-A dated 06/29/17)
- Structure print prepared by Effective Engineering Solutions (Drawing No. 72120 dated 07/07/17)
- Formetco Digital Print (Drawing No. B-2712 - 2 pages)
- Certificate of Insurance

If you require any additional information, please don't hesitate to contact me direct at 610.403.4229. Please let us know any monies due and we will remit promptly. Thank you.

Sincerely,

Jodi A. Cesanek
Real Estate Representative

Enclosures

UPRIGHT BEAM CLAMP
SEE PG 3 FOR QTY & FAB DETAILS
SECURE WITH 1/2"-13 GR5 HDWR

UNISTRUT SPLICES
SEE PG 3 FOR QTY & FAB DETAILS
SECURE WITH 1/2"-13 GR5 HDWR

ON-SITE SERVICE REQUIREMENTS

- 1) THE DISPLAY MUST BE ACCESSIBLE THROUGH USE OF A 20 FOOT OR SHORTER LADDER.
- 2) THERE MUST BE A SECURE CATWALK OR BASE FROM WHICH SERVICE MAY BE PERFORMED.
- 3) ALL REAR SERVICED DIGITALS REQUIRE CATWALKS SPACED AT NO GREATER THAN 7'-6" IN HEIGHT.
- 4) THERE MUST BE A GUARD RAIL OR A SAFETY LIFELINE SECURELY ATTACHED TO THE SUPPORT STRUCTURE IF THE DISPLAY IS OVER 6 FEET OFF THE GROUND COLLECTIVELY AN ACCESSIBLE SITE? IN THE ABSENCE OF AN E-DESIGNATED SAFE ACCESS ON THE DISPLAY SERVICE MUST BE PERFORMED ONLY IF THERE IS SAFE ON-SITE ACCESS IN COMPLIANCE WITH APPLICABLE FEDERAL AND LOCAL LAWS AND REGULATIONS.

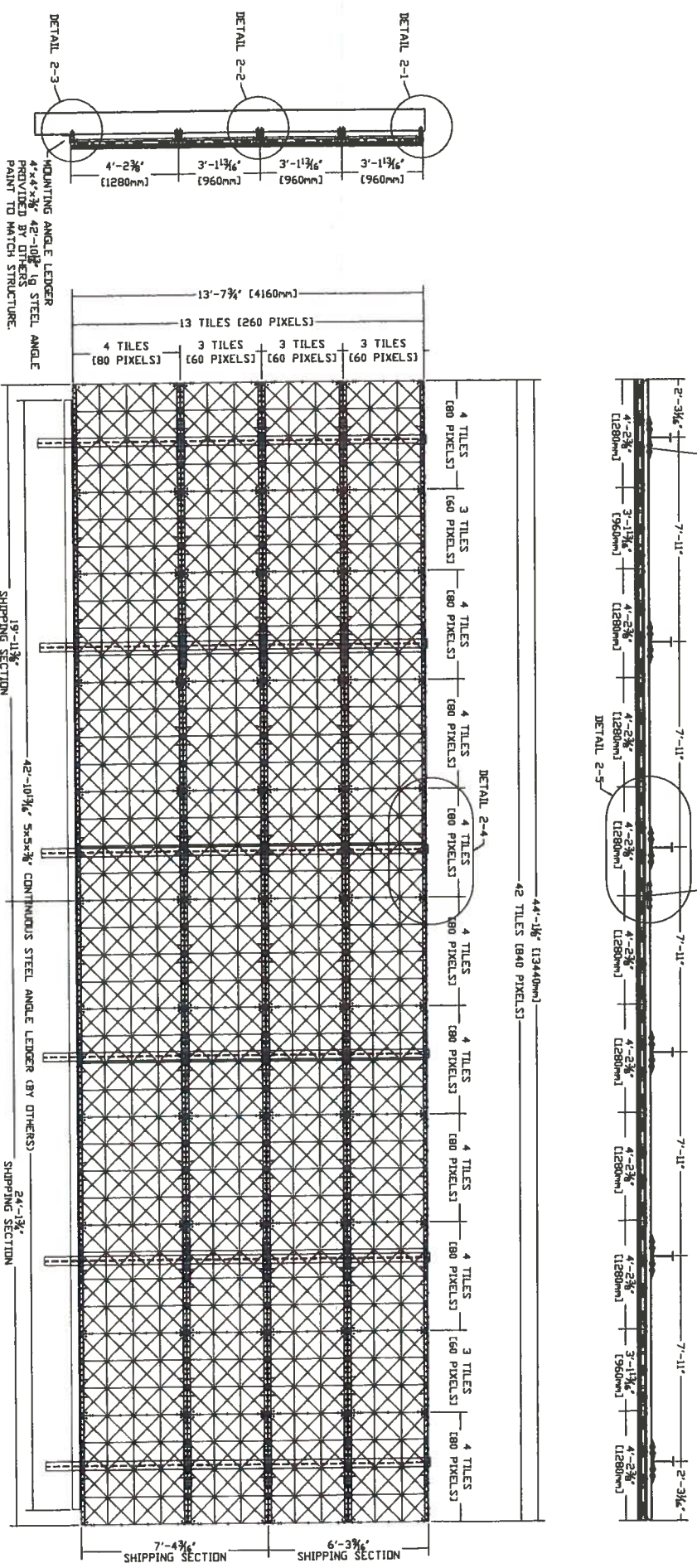

SEE B-2712 FOR POWER RISER AND DATA LAYOUT

DESIGN REQUIREMENTS PER
IBC 2012/FBC 2010/ASCE 7-10, 165 mph,
MAXIMUM UPRIGHT SPACING: 8'-4 1/4" (2560mm),
ALLOWABLE CANTILEVER: 4'-2 3/8" (1280mm) MAX.

APPROXIMATE SIGN WEIGHT without TRIM
MOUNTING STRUT AND BRACKETS:
ELECT SYSTEM:
F-TILE LED MODULES:
TRIM - 3" ANGLE
CABLING
TOTAL

904#
130#
4,913#
0#
132#
6,099#

REV	DESCRIPTION	DATE	APPD
-	DESCRIPTION <td></td> <td></td>		
	REVISIONS <td></td> <td></td>		

THIS MATERIAL IS THE EXCLUSIVE CONFIDENTIAL PROPERTY OF FORMETCO, INC.
ALL RIGHTS, INCLUDING COPYRIGHT AND PATENT RIGHTS ARE RESERVED TO FORMETCO, INC.
DO NOT COPY THIS DRAWING WITHOUT PERMISSION OF FORMETCO, INC.

PART NUMBER	FTY++ DBB
APPROVALS	
DATE	07-17
ISSUED	7-12-17
DO NOT SCALE THIS DRAWING	
SCALE	1:50
DWG NO.	B-2712
SH	1 OF

FORMETCO
2963 Pleasont Hill Rd. Duluth, GA 30096-380

16mm 280 x 840 DBB UNISTRUT MTG
STANDARD 13-7 x 44-1" 16mm F-TILE DBB

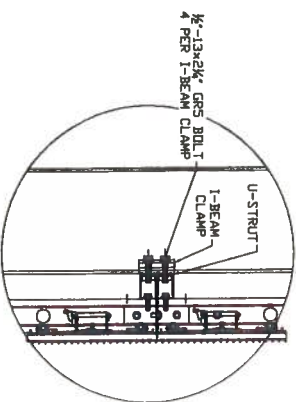
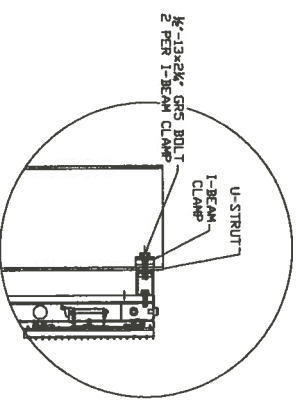
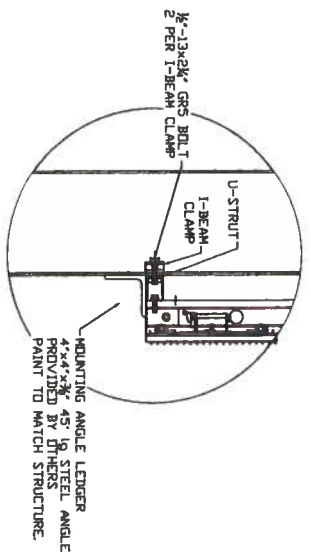
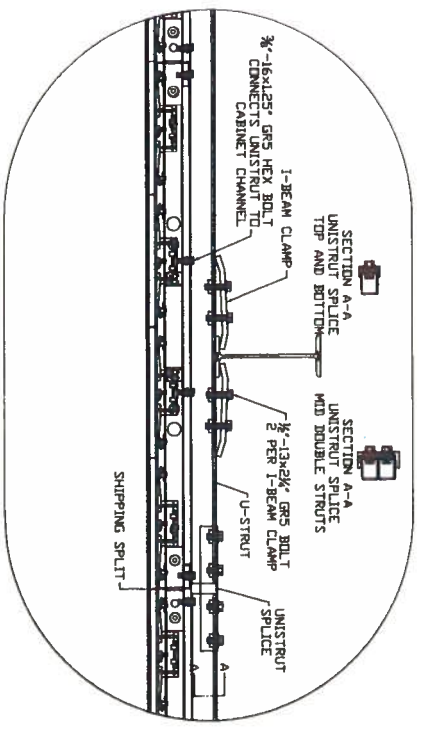
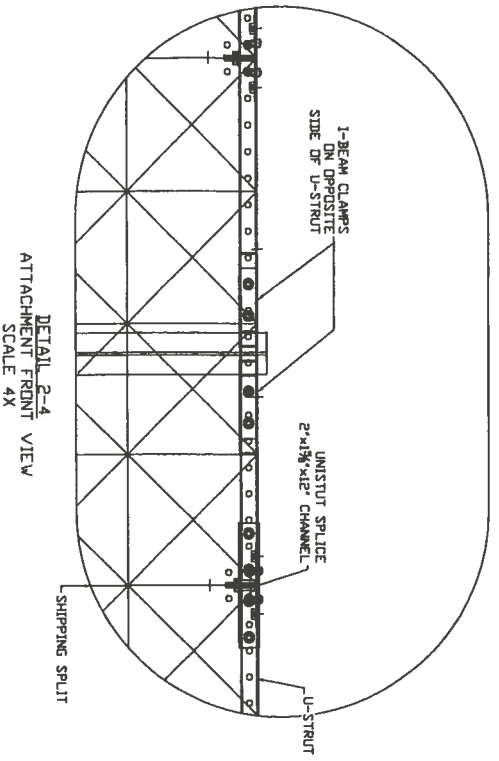

DETAIL 2-5
TYP ATTACHMENT AT UPRIGHTS
ASSY IN FIELD BY OTHERS
SCALE 4X

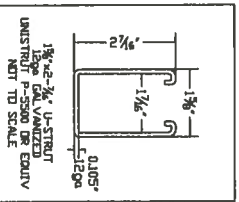

1 3/4\"/>

REV	DESCRIPTION	DATE	APPD
-	REVISIONS		
	THIS MATERIAL IS THE EXCLUSIVE CONFIDENTIAL PROPERTY OF FORMETCO, INC. ALL RIGHTS, INCLUDING COPYRIGHT AND PATENT RIGHTS, ARE RESERVED BY FORMETCO, INC. DO NOT COPY THIS DRAWING WITHOUT PERMISSION OF FORMETCO, INC.		

PART NUMBER	FTX++ DBB
APPROVALS	
DATE	07-12
UPDATE	7-12-17
DO NOT SCALE THIS DRAWING	
SCALE	1:50
DWG NO.	B-2712
SH	2
DR	

FORMETCO

2963 Pleasant Hill Rd. Duluth, GA 30096-3808

UNISTRUT UPRIGHT CONNECTION DETAILS
STANDARD 13-7/44-1" 16mm F-TILE DBB



July 5, 2017

To Whom It May Concern:

Acting in its capacity as location agent for the Norfolk Southern Railway, Right Angle Media, Inc. hereby authorizes Adams Outdoor Advertising or anyone acting on their behalf to apply for any and all local and state permits necessary to construct signboards at the following location in the City of Bethlehem, Pennsylvania

- 1.) RAM / 210(rev) ES Route 378 s/o Lehigh River

Any questions may be addressed to me at the number listed below.

Sincerely,

Robert F. Orlando
President

RIGHT ANGLE MEDIA, INC.

SITE DATA

OWNER: PENNSYLVANIA LINES, LLC
 C/O NORFOLK SOUTHERN RAILWAY CO.
 SITE ADDRESS: 231 UNION STATION PLACE
 BETHLEHEM, PA
 RECORDING REFERENCE: VOL 2003-1, PG. 434659
 TAX PARCEL: P6-2-1/TOTAL AREA:

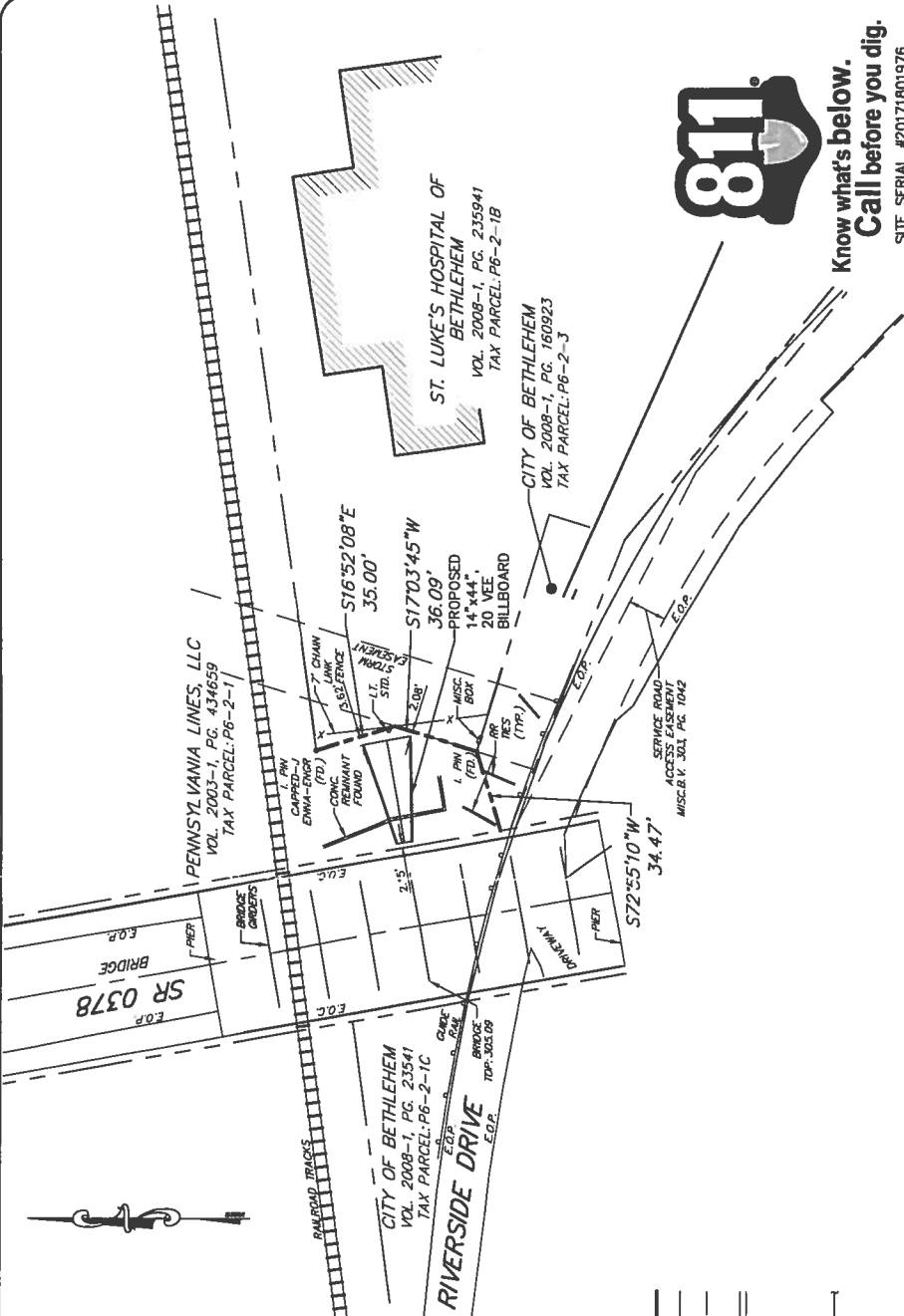

**Know what's below.
 Call before you dig.**
 SITE SERIAL #20171601976

LEGEND

- PROPERTY BOUNDARY
- LOT LINE
- EASEMENT
- CURBING
- BUILDING
- CHAIN-LINK FENCE
- SPOT ELEVATION
- EDGE OF PAVEMENT
- EDGE OF CONCRETE

NOTE:
 VERTICAL TEXT INDICATES PROPOSED FEATURES
 SLANTED TEXT INDICATES EXISTING FEATURES



JOB NUMBER:	1017317.000
DATE:	06/29/17
SCALE:	1"=50'
DRAWN BY:	DES
SHEET:	EX-A

EXHIBIT A
 NORFOLK SOUTHERN RAILWAY CO.
 ADAMS OUTDOOR ADVERTISING, LP
 CITY OF BETHLEHEM
 NORTHAMPTON COUNTY, PA

BARRY
BISETT &
associates
 610.391.0904
 barybi@att.net

NOTES

- 1) Provide frame base on all conditions of existing site, after correct clearing, grading and drainage has been established.
- 2) This structure has been designed to support (1) 2000 lb. dead load, (2) 100 psf live load, and (3) 100 psf snow load. It is not designed to support any other loads.
- 3) Design a connection of cube footing and upright to support to foundation, as shown.
- 4) Provide 3/4" dia. pipe for all of frame pipe. Cap should be provided, as shown, to pipe.
- 5) Member columns to be spaced 7' 6" on center (7' 6" x 7' 6" spacing).
- 6) Column spacing to be 21' 0" o.c. (21' 0" x 21' 0" spacing).
- 7) (a) to column center line 4" dia. steel pipe, 1" x 10' x 1/4" (b) to column center line 4" dia. steel pipe, 1" x 10' x 1/4"



TYPICAL GUSSET DETAIL

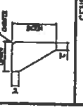

GENERAL NOTES

- 1) All steel shall be A36 steel, unless otherwise specified.
- 2) All connections shall be welded, unless otherwise specified.
- 3) All steel shall be galvanized, unless otherwise specified.
- 4) All steel shall be painted, unless otherwise specified.
- 5) All steel shall be fireproofed, unless otherwise specified.
- 6) All steel shall be protected from corrosion, unless otherwise specified.
- 7) All steel shall be protected from rust, unless otherwise specified.
- 8) All steel shall be protected from weather, unless otherwise specified.
- 9) All steel shall be protected from UV radiation, unless otherwise specified.
- 10) All steel shall be protected from acid rain, unless otherwise specified.
- 11) All steel shall be protected from salt crystallization, unless otherwise specified.
- 12) All steel shall be protected from scale, unless otherwise specified.
- 13) All steel shall be protected from stress corrosion cracking, unless otherwise specified.
- 14) All steel shall be protected from hydrogen embrittlement, unless otherwise specified.
- 15) All steel shall be protected from fatigue, unless otherwise specified.
- 16) All steel shall be protected from brittle fracture, unless otherwise specified.
- 17) All steel shall be protected from creep, unless otherwise specified.
- 18) All steel shall be protected from creep rupture, unless otherwise specified.
- 19) All steel shall be protected from creep-fatigue interaction, unless otherwise specified.
- 20) All steel shall be protected from creep-fatigue crack growth, unless otherwise specified.

2018 IBC (15 mph - Exp. C) - Bldg. Cat. I

Effective: Philadelphia Subdivisions, LTD.
 61 North 15th Street
 Philadelphia, PA 19102
 (615) 484-1474

1" x 10' x 1/4" dia. steel pipe - 20' x 20' x 1/4" steel pipe

LED Structure of Vertical Overhead Heights

Alarm Outdoor Advertising

USE THESE CONNECTIONS FOR ALL STRUCTURAL STEEL CONNECTIONS AND SHALL NOT BE USED FOR ANY OTHER PURPOSES. THE ENGINEER'S RESPONSIBILITY IS LIMITED TO THE DESIGN OF THIS CONNECTION.

DATE: 7/11/17

7/11/17

7/11/17

7/11/17

7/11/17

7/11/17

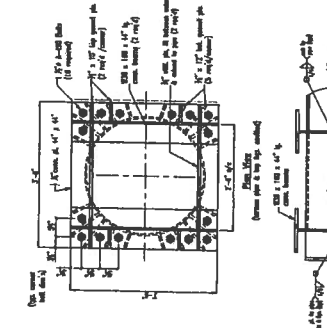

1 Plan View

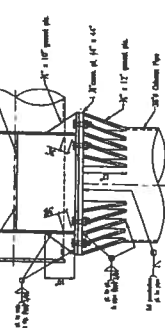

2 Front Elevation

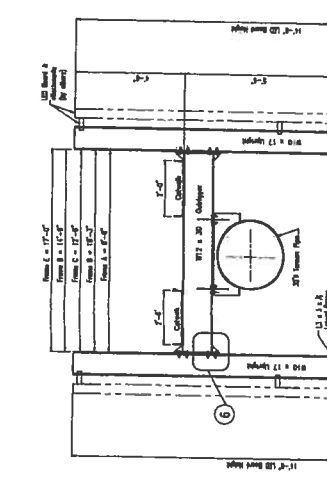

3 Frame Detail

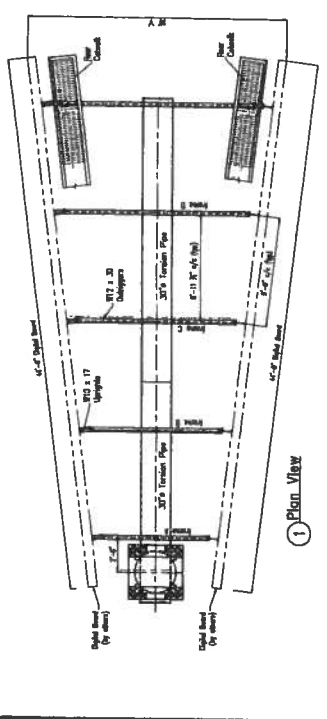

4 Column & Footing Schedule

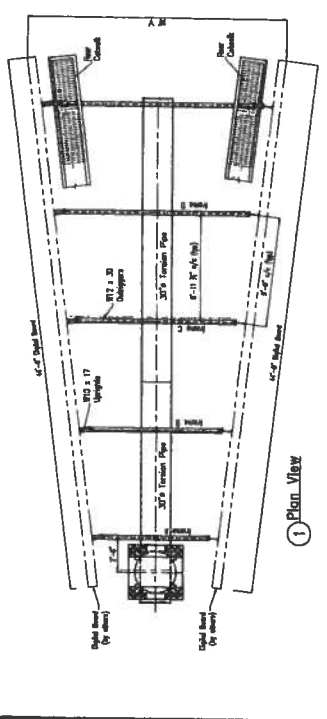

5 Cube Footing Plan

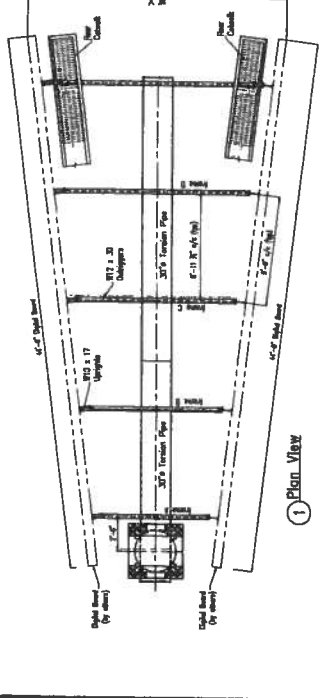

6 Rear Ledger Connection

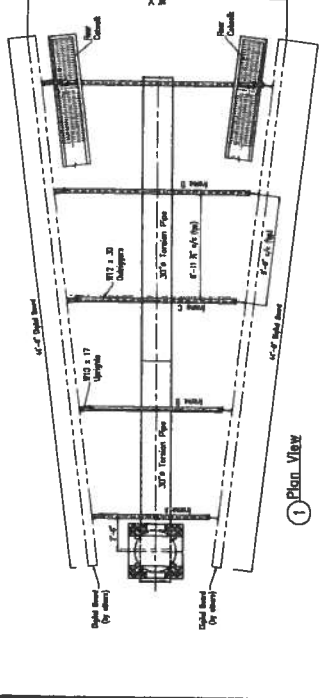

7 Column Splice Detail

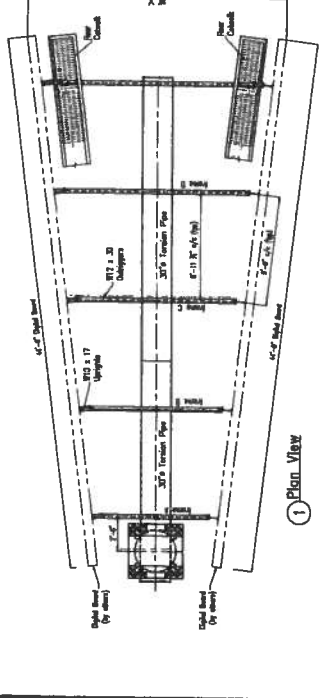

8 Outrigger & Upright Connection

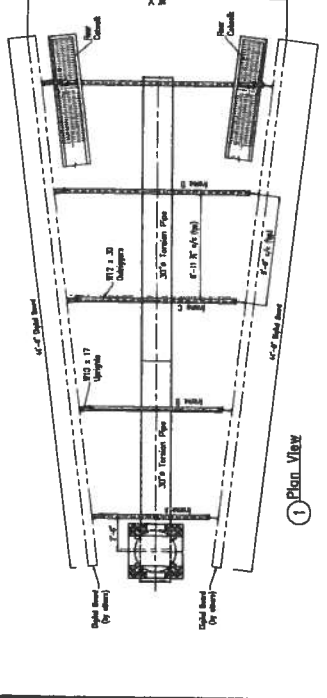

9 Alternate Cube Footing